

EINSTEIN 6100 FFE (FALLING FILM EVAPORATOR) CONTINUOUS-FEED ETHANOL EVAPORATION AND RECOVERY SYSTEM

EVAPORATION/RECOVERY RATE: 45 GPH (170L)
 SOLVENT: ETHANOL, DENATURED ETHANOL
 TURN-KEY SYSTEM, ON-SITE INSTALLATION, PERSONAL INSTRUCTION

INCLUDED:

- ALL ANCILLARY EQUIPMENT:
 CHILLER
 HEATER
 PUMPS
- ACCESSORIES:
 CRUDE COLLECTION POT, ETHANOL RECOVERY TANK, COMPR. AIR KIT

ELECTRICAL REQUIREMENTS:

95A @480V, 3-PHASE
 8.5A @120V, 1-PHASE

EXCEPTIONAL QUALITY:

SKILLFULLY DESIGNED, DEFTLY MANUFACTURED, AND PROUDLY OVERBUILT IN OREGON, USA
 ASME-CERTIFIED WELDERS
 FDA COMPLIANT
 FOOD-GRADE MATERIALS

EXPRESS WARRANTY ON ALL PARTS MANUFACTURED BY SUBZERO SCIENTIFIC

SAFETY AND CODE COMPLIANCE:

3RD PARTY CERTIFIED FOR SAFETY AND CODE COMPLIANCE FOR STATE, NATIONAL, AND INTERNATIONAL CODES
 STATE CERTIFICATIONS: WA, OR, CA, NV, AZ, CO, MN, MI, VT, ME, MA, MD, DC, NM, OK
 COMPLIANCE: IFC 2018 SECTION 5003.2, NFPA 30-2018, NFPA 70-2017, ASCE/SEI 7-10
 CONTROL AREA REQUIRED FOR CLASS IB, GROUP D FLAMMABLE LIQUID:
 PER IFC 2018, 5003.8.3/IBC 2018, 414.2

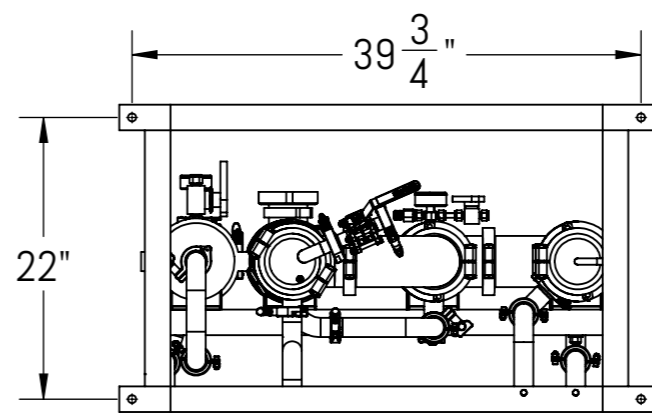

MOUNTING HOLES
(1/2" BOLTS)

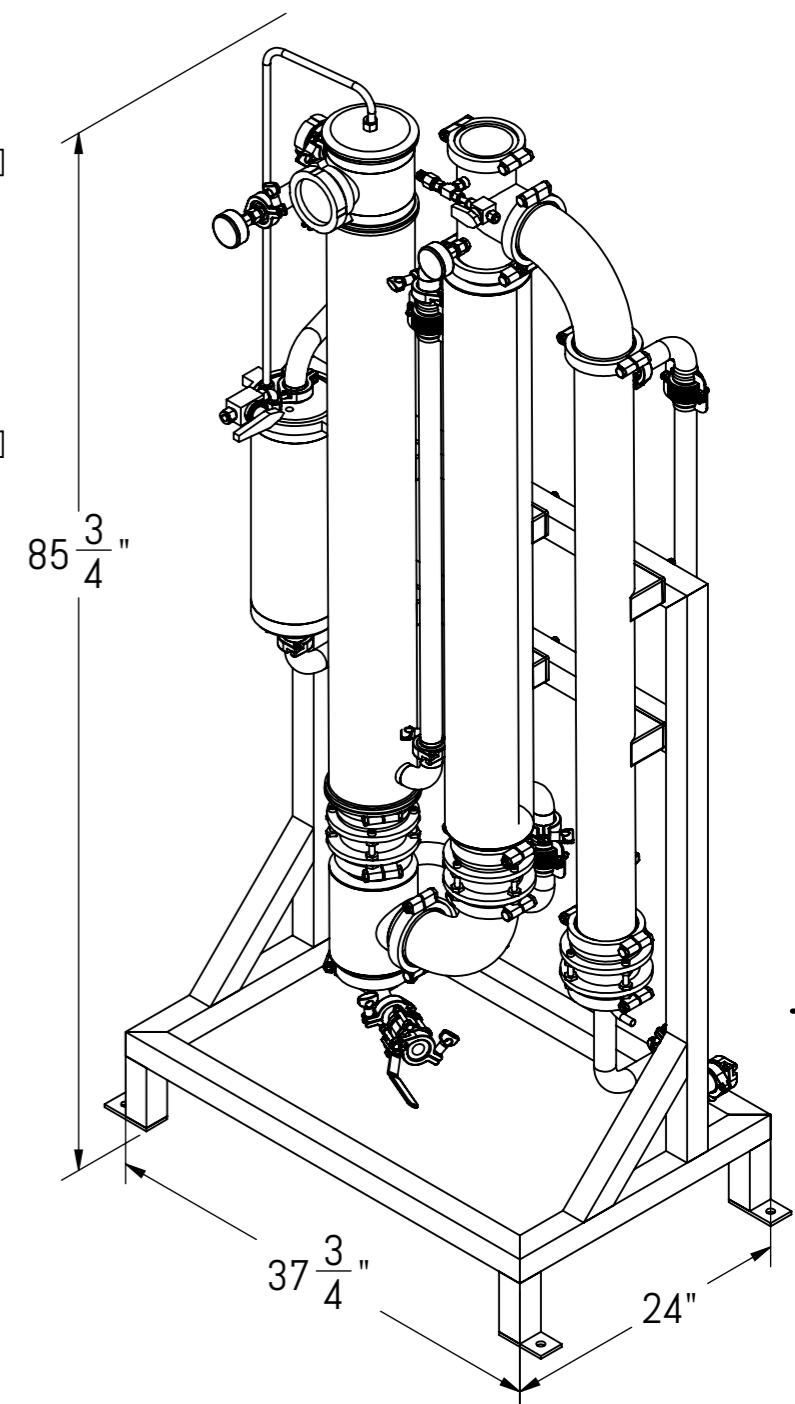

(GAS HEATER OPTION)

Subzero Scientific, LLC provides this material as a general guide for our valued customers. No recommendation, proposal, review, or approval of plans, specifications or other information or documentation by Subzero Scientific, LLC shall constitute a representation or warranty that such plans, specifications or other information or documentation satisfy any applicable laws or other requirements or will provide for a safe operation, and no such review or approval shall make Subzero Scientific, LLC otherwise liable with respect thereto. Customers shall be solely responsible for determining whether its plans, specifications, construction and maintenance meet its needs, satisfy applicable laws and other requirements and will provide for safe operation.

SUBZERO SCIENTIFIC <small>710 NE CLEVELAND AVENUE, SUITE 120, GRESHAM, OR 97030</small>		PROJECTION METHOD: THIRD ANGLE 	DESCRIPTION: EINSTEIN 6100 FFE PRODUCT SPECIFICATION	
		WEIGHT: 550 LBS	DRAWN BY: MJG	DRAWN DATE: 8/27/2019
PROUDLY OVERBUILT IN OREGON		MATERIALS: FDA COMPLIANT	CHECKED/APP'D BY: LS	CHECKED DATE: 8/27/2019
UNLESS OTHERWISE SHOWN, DIMENSIONS ARE IN INCHES.		FOOD-GRADE	MODEL NUMBER: 900101-001	
DRAWING STANDARD: BS8888	DO NOT SCALE DRAWING	DOCUMENT TYPE: PRODUCT SPEC. SHEET	DRAWING NUMBER:	SHEET: 1 of 1
			REVISION: 1	